

MANUFACTURING

Screws and Nuts

www.warburtons.com.au

MANUFACTURING SCREWS AND NUTS

4.1 Manufacturing processes

In principle, the following manufacturing processes are differentiated:

On the one hand there is forming without cutting and on the other, machining. With forming without cutting there is a further differentiation between cold and hot forming.

The following diagram is intended to make the production processes clearer:

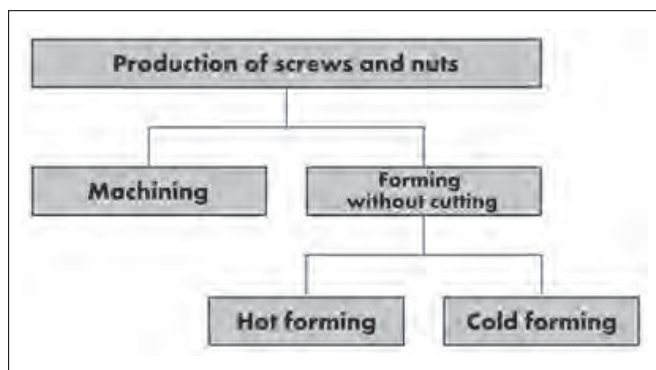

Fig. N: Overview of the various production processes

4.1.1 Cold forming (cold extrusion)

In modern fastening technology the majority of fasteners are made using the cold forming procedure. In this procedure, the fastener is formed, usually in multistage processes, by pressure forging, cold extrusion and reducing, or a combination of these procedures. The term solid or cold forming was coined for this type of production.

This procedure is usually used for large quantities, because, from an economic aspect, it is the most rational method.

The choice of the suitable forming machine depends on the size of the fastener and on the degree of forming. The greater the degree of forming, the more forming stages are required. Sharp-edged transitions or thin profiles are unfavourable for cold forming and lead to increased tool wear.

A decisive role for the quality of the final product is played by the choice and the quality of the input material

(wire). Screw manufacturers usually receive the wire coiled on rolls that often weigh over 1000 kg.

The wire is normally phosphate treated to enable the wire to be worked perfectly and to minimise tool wear.

The designer of a screw or a fastener tries during development to harmonise the advantages and disadvantages of the different materials with the requirements specified for the fastener. With the materials differences are made, along with corrosion-resistant steels, between unalloyed and alloyed steels. For example, if increased strengths are required, it is absolutely essential to subject the parts after pressing to a heat treatment process in order to be able to influence the mechanical properties specifically.

Diagram of the stages for a hexagon head screw

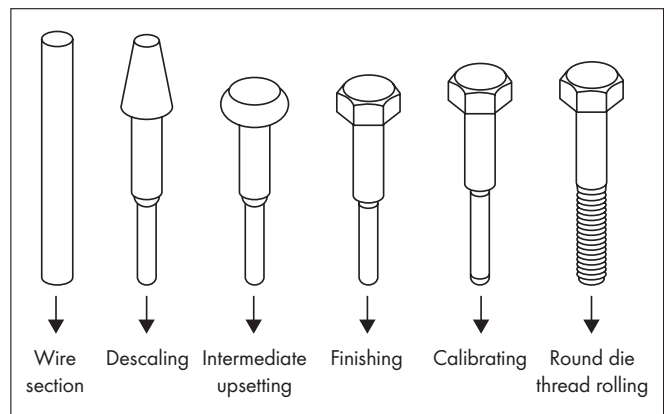

Nuts are usually produced with the cold or hot forming procedure as well. The choice of one or the other procedure depends on the one hand on the size and on the other on the required quantities.

MANUFACTURING SCREWS AND NUTS

Diagram of the stages for a hexagonal nut

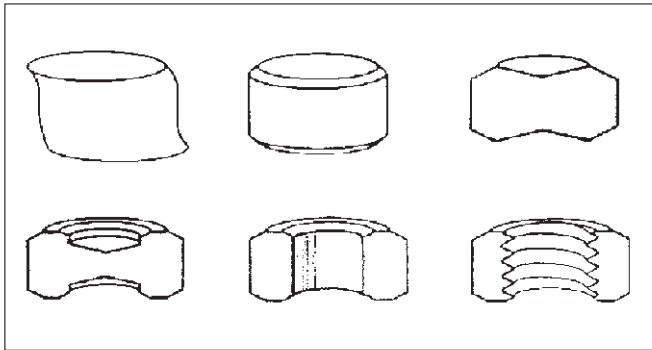

Advantages of cold forming:

- Optimal use of material
- Very high output
- High dimensional accuracy and surface quality
- Increase of strength properties through strain hardening
- Run of the chamfers in press parts in accordance with the load

4.1.2 Hot forming

This production method is used mainly to manufacture large diameters starting with approx. M27, and longer pieces starting from approx. 300 mm. In addition, parts are possible that cannot be produced using cold forming because of the very small volumes, or because of a very high degree of forming.

With this procedure, the input material (usually bars) is heated wholly or partially to forging temperature. This heating up enables even complicated geometries or very high degrees of forming to be realised. A typical feature for a hot-formed component is the raw surface structure. Strain hardening is not carried out during hot forming!

Advantages of hot forming:

- Enables production of complicated geometries
- Low production runs
- Large diameters and lengths

4.1.3 Machining

Machining is usually understood as processing steps such as turning, milling, grinding or reaming. The most common method with regard to fasteners is turning, but this has lost a great deal of importance because of the technical possibilities of cold pressing.

During turning, the required contour of the component is cut from the input material using a turning tool. The diameter of the input material depends on the largest diameter of the component. Usually, bars with a length of up to 6 m are used. In contrast to cold or hot forming, the chamfer course of the input material is destroyed.

This production procedure is used either if the production run is not very large or if the part geometry cannot be complied with in cold or hot forming procedures because of sharp edges, small radiuses or even nominal sizes. Surface roughnesses of Ra 0.4 or Rz 1.7 can be achieved with this production procedure without any problems. In the case of large production runs the blanks are often produced with the cold extrusion method and are then machined.

4.2 Thread production

Where screws are mass-produced, the thread is usually formed or rolled. In this procedure, the screw is rolled between two rolling dies (flat dies), one of which is fixed and the other running, and this creates the thread (see the diagram). With this type of thread production it is possible to fit several hundred screws per minute with a thread. The thread is usually applied before hardening and tempering. If special requirements mean that the thread is applied after the heat treatment process, the thread is referred to as "finally rolled".

MANUFACTURING SCREWS AND NUTS

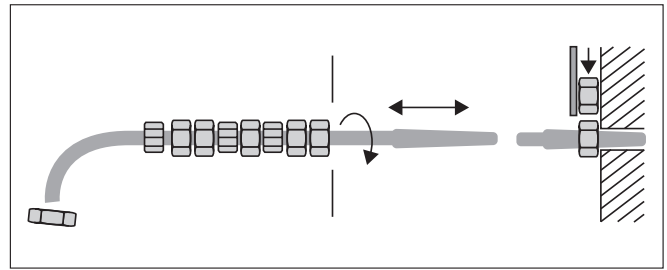
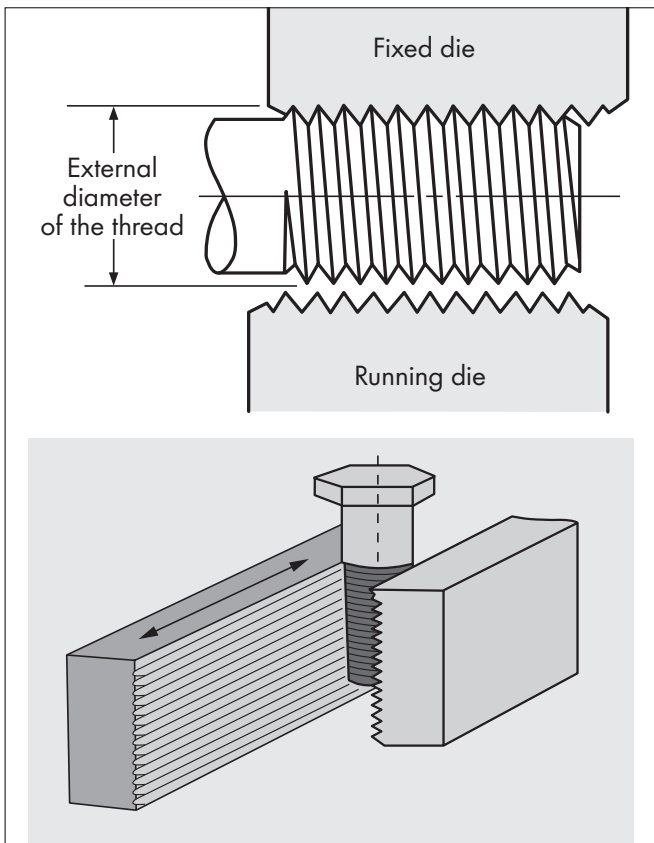

Thread cutting on an automatic lathe with a taper tap

4.2.1 Fibre pattern

The two diagrams show very clearly the differences between a rolled and a cut thread. With thread forming the material is work hardened again in addition, and the fibre pattern is not interrupted. In this case, the original diameter of the screw is approximately the same as the flank diameter. With thread cutting, the original diameter of the screw is the same as the nominal diameter of the thread. The fibre pattern is interrupted by the cutting.

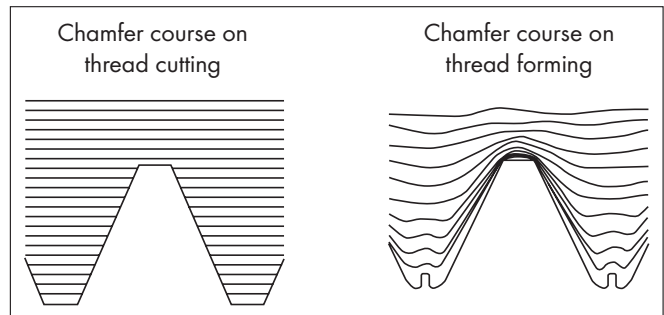

Other methods for making threads:

Plunge cutting

Tool rolls that are driven at the same speed rotate in the same direction. The workpiece rotates without being axially displaced. This method can be used to make threads with very high pitch accuracy.

Continuous method

The thread pitch is generated by inclining the roller axes by the pitch angle. The workpiece is given an axial thrust and moves by one thread pitch in an axial direction, with a full rotation. Overlength threads can be made in this way.

Thread cutting

In this procedure the thread is made by means of a tap or a screw stock. With screws, this procedure is mainly used for very low production runs or with machined parts as well.

However, things are different when a female thread is made. In this case the thread is usually cut with a screw tap or taper tap.

4.3 Heat treatment

4.3.1 Hardening and tempering

The combination "hardening" and subsequent "tempering" is referred to as hardening and tempering.

DIN EN ISO 898 Part 1 prescribes hardening and tempering for screws from strength class 8.8, and DIN EN 20898 Part 2 prescribes it for nuts in strength class 05 and 8 (>M16), and from strength class 10.

4.3.2 Hardening

The screw is heated to a specific temperature among other things in dependence on its carbon content and kept at this temperature for a long period. This changes the microstructure. A great increase in hardness is achieved through the subsequent quenching (water, oil, etc.).

4.3.3 Annealing

The glass-hard and therefore brittle material cannot be used in practice in this condition. The material must be heated up again to a minimum temperature specified in the standard, in order to reduce the distortions in the microstructure. It is true that this measure reduces the hardness that was reached beforehand (but this is much higher than the values of the untreated material), but greater ductility is achieved. This procedure is an important aid for manufacturers to make screws that satisfy the requirements demanded by users.

4.3.4 Case hardening

This procedure is used among other things for tapping screws, thread grooving and self-drilling screws. In this case, very hard surfaces are decisive, so that these screws are able to make their own thread automatically. The screw core, in contrast, is soft.

Steels with a carbon content of 0.05% to 0.2% are used for these types of screws. The steels are heated and kept for a long time in an atmosphere that gives off carbon (e.g. methane). The carbon diffuses into the surface zones and in this way increases the local carbon content. This process is known as carburisation. Finally, the material is quenched and in this way hardened in the surface zones. This has the advantage that the surface is very hard, but sufficient ductility remains in the core of the screw.

4.3.5 Stress relief annealing

There are a number of different annealing procedures which have different effects in each case on the microstructure and the states of stresses in the material. One very important procedure in the context of fasteners is stress relief annealing (heating to approx. 600°C and maintaining this temperature for a long period). The strain hardening created on cold forming can be reversed by stress relief annealing. This is particularly important for screws in strength classes 4.6 and 5.6, because here there has to be a large elongation of the screw.

4.3.6 Tempering

Tempering is the thermal treatment of high strength components (strengths ≥ 1000 MPa or hardnesses ≥ 320 HV) with the aim of minimising the risk of hydrogen embrittlement. Tempering must be carried out at the latest 4 hours after the conclusion of the galvanic surface treatment. The minimum temperature depends on the strength classes or on the materials that are used.